

Assembly Instructions

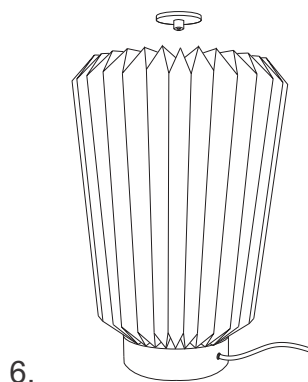
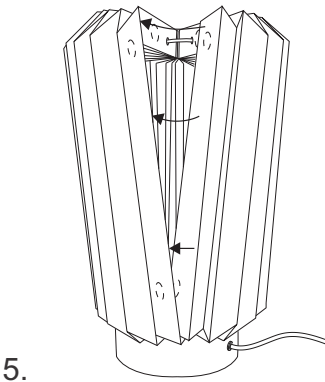
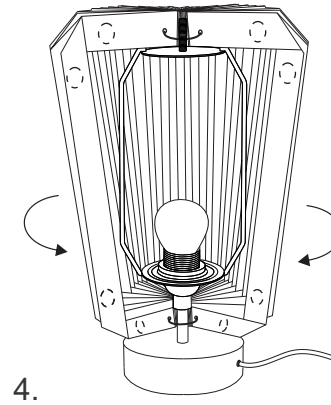
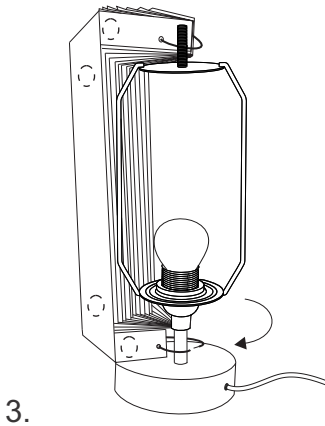
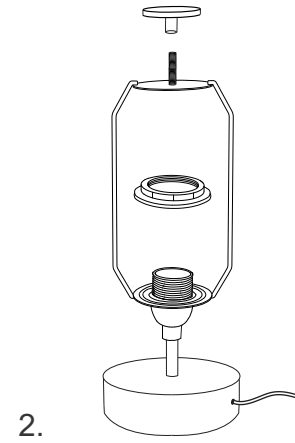
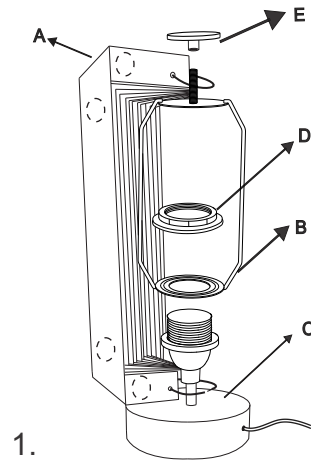
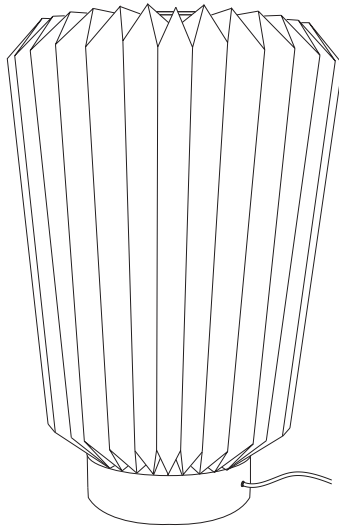

Box contains following lamp parts:

- A. Paper Shade
- B. Harp
- C. Lamp Base
- D. Shade Ring
- E. Finial
- F. Additional bottom ring (supplied in case of damage to original ring)

1. Place harp on lamp holder and tighten shade ring. Carefully fix the bulb. (not supplied with the product).

2. Gently open bottom ring of the shade as shown in the image. Close the ring carefully (bottom ring has been marked in the shade).

3. Bring both edges of shade together around the harp. Top ring of shade should pass through harp stud.

4. Please ensure that the last flap of the shade overlaps so that it closes securely. There are hidden magnets behind the last flap. Press points gently for a few seconds to allow the magnets to connect and hold the shade in place.

5. Tighten the finial on harp stud.
Your Lamp is now ready to lit up.

Attention

Use LED light source only , max 10 W. Sold separately. Keep out of reach of small children and burning candles